

'Talking' Telemedicine: Is the Interactive Voice-Logbook Evolving into the Cornerstone of Diabetes Healthcare?

Black, L., McTear, M., Black, N., Harper, R., and Lemon, M.

Faculty of Engineering,
University of Ulster at Jordanstown,
Northern Ireland.

www.ulster.ac.uk

Presentation Overview

- Problem Definition
- Introducing the DI@L-log System
- Highlight Design Features & Considerations
- Integration and Testing
- Methodology
- Results
- Conclusion

www.ulster.ac.uk

Type 2 Diabetes and Hypertension- combining conditions

- Nearly 50,000 affected by Type 2 diabetes in Northern Ireland. It is estimated at least 60% of these patients have co-existing hypertension
- Frequently no symptoms
- Complications
- NHS costs 5.2 billion per annum (Tardis Report)
- UKPDS trials advocate regular monitoring
- More people will get the disease (aging population, sedentary lifestyle, unhealthy diet = more obese patients)
- Lack of control and communication (paper logbook)

www.ulster.ac.uk

Home Monitoring; A Twofold Perspective

Patients' View

- Lack of regular contact, support & education from the point of care
- Compliance is an arduous task (forget medication, feel controlled)
- Paper logbook is static - does not promote advice, feedback, incentive



Physician Perspective

- Less than 1/4 of patients make necessary lifestyle changes
- Lack of time, financial, human resources, accountability
- More patients, more information generated
- Paper logbook often incomplete, illegible
- Doctors do not like entering data

www.ulster.ac.uk

Diabetes Management Solutions

- **DIABNET** - knowledge-based system which produces advice on insulin therapy adjustments and diet recommendations for patients with gestational diabetes. Patients use palm-top computers.
- **IDEATel** - Disease management program in rural and urban underserved areas. Home telemedicine unit used for blood glucose downloading and videoconferencing.
- **DIABCARD** - Uses smart cards as means of collecting patient data. Clinician uploads data to cards at the point of care.
- **DIAMOND** - Diabetes electronic patient management (EPR) system used by 40 health institutions in UK

www.ulster.ac.uk

DI@L-log Prototype

- A spoken dialogue system for the acquisition of type 2 diabetes (T2DM) home monitored patient data is proposed, known as **DI@L-log**.
 - The purpose of the system is to collect:
 - **Weight**
 - **Blood sugar**
 - **Blood pressure**
- readings from hypertensive T2DM patients on a weekly basis using their home telephone. The system incorporates the latest speech technologies in conjunction with artificial intelligence techniques.

www.ulster.ac.uk



Why the Telephone in Medicine?

- The PSTN is the simplest and oldest form of telemedicine
- As a neutral source of empowerment over the paper logbook
- Overcome constraints of space and time
- No expert knowledge or modem required (microphone/speaker as input-output devices)
- Ubiquitous - more telephone lines than computer terminals
- Practical- extends to remote/isolated areas (24/7)
- User has choice of input (Speech or DTMF)
- More cost effective than some exclusive technologies (many patients from socially deprived backgrounds)



DI@L-log "Voice" Logbook

- DI@L-log is intended as an autonomous communication intervention whose design improves the traditional paper logbook used to document home readings by the patient, via a seamless medical information exchange infrastructure that scales to the needs of multiple end users.
- System architecture integrates VoiceXML + PSTN, with a Pan-European open architecture for hosting integrated telephony applications.
- TCP/IP connections to a database enable patient information to be dynamically updated and relayed to the point of care EPR.

System Architecture

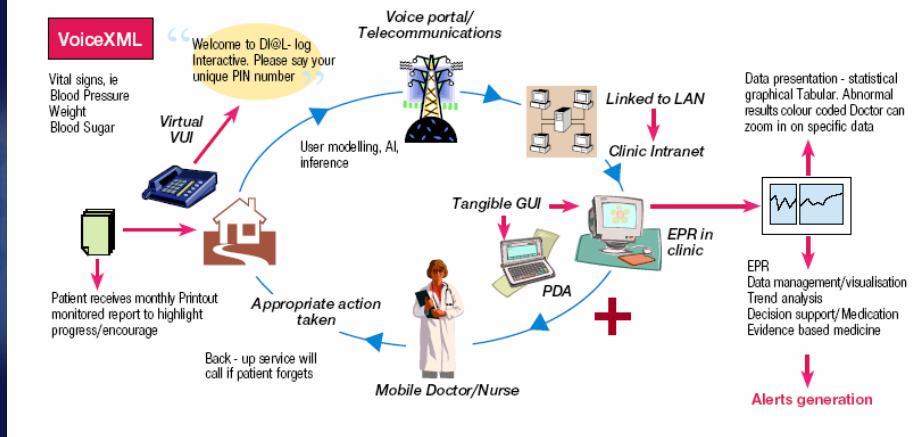

Design Characteristics

- DI@L-log is a 'female', application-directed system
- Supports speaker independent interaction
- Adaptive to novice & expert users (Full Duplex)
- Explicit confirmation protocol at each interaction to minimize ambiguity
- Universal navigation help, repeat & exit commands
- Uses a variety of incremental and tapered prompts

System:	Welcome to the DI@L-log Interactive Service. You can say 'help' or 'exit' at anytime. Please now enter your 4 digit PIN
User:	It's 1 9 7 5
System:	You said 1 9 7 5 is that correct?
User:	Yes
System:	One moment, I'm looking up your details...Hello John Mann, what is your weight today?
User:	My weight is 17 stone, 5 pounds today.
System:	You said your weight was 17 stone and 5 pounds, is that correct? Please say yes or no.
User:	(pauses)
System:	Please confirm your weight was 17 stone and 5 pounds.
User:	That's right
System:	Thank you, and what is your blood sugar reading?

Task Model Sequence and Event Handling

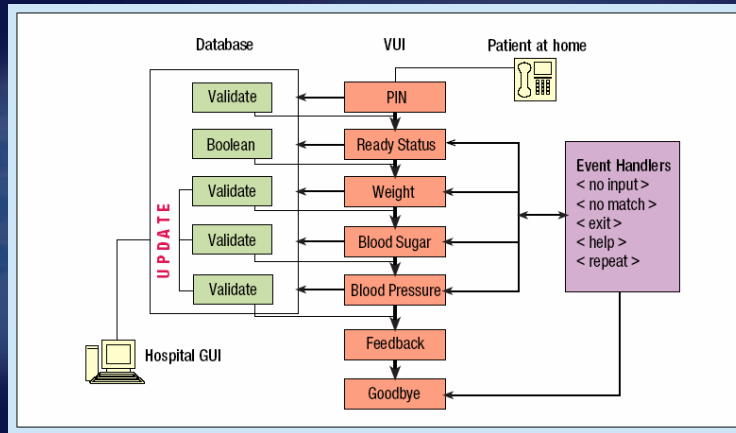

Technology and Tools Employed

VUI (Voice User Interface)

VoiceXML 2.0

XML coded grammars (custom, built-in and DTMF)

VoxPilot- Internet Voice Browser provider

Backend Subsystem

MS Access Database via ODBC

Apache Tomcat 4.0

JSP

SQL

GUI (Graphical User Interface)

Visual Basic 6.0

Photoshop

Requirements Analysis and Testing Methodology

- Questionnaires to T2DM patients (n=32) at UCHT to determine user needs and profiles –demographics, compliance issues, use of mobile and standard telephones, computer literacy and impressions of Spoken Dialogue Systems (SDS)and collect word vocabulary.
- Focus group sessions held, training of devices provided.
- WOZ and rapid prototyping techniques employed on patients (n=5) and a combination of health professionals and academic peers (n=7) in development of VUI and GUI.
- Simulations were then fed to the system of real patient data sets (n=10) from a 3 year time frame to test accuracy of decision support functionality
- There is a pre-pilot study currently underway
- Full 6-9 month pilot will be rolled out to 20 T2DM patients from Institute of e-Health at the Ulster Hospital in January.

www.ulster.ac.uk

System Intelligence & Domain Knowledge

- Specific order created for users to acquire consistent mental model
- Production rules written according to medical protocols, refined by medical experts.
- Protocols and domain knowledge used to compute differences from one week to the next by consulting previous patient measurements and user targets held in the database

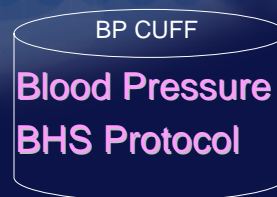
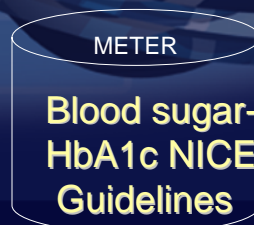
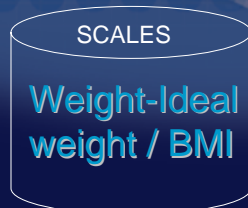

www.ulster.ac.uk

Rule Based Intelligence Thresholds

Weight Lowers BMI, obesity levels, reduces likelihood of hypertension, increases insulin sensitivity	Sugar (mmol/l) Control of the HbA1c will reduce microvascular complications (eyes and kidneys)	Blood Pressure (sBP, dBP) Reduces cardio and macrovascular complications (heart disease, myocardial infarction, stroke)
- At or below target - Above target but falling - Above target and stable - Above target and increasing (<2lb) - Above target and increasing (≥2lb)	< 4 - needs monitored carefully ≥4 and ≤ 7 - good control > 7 and ≤ 11 - slightly raised >11 and ≤ 17 - high, needs monitored carefully > 17 - very high; patient should contact the hospital	sBP ≤ 140 irrespective of dBP Good control sBP > 140 and ≤160 irrespective of dBP - Raised blood pressure sBP > 160 and ≤ 180 irrespective of dBP- Significantly raised blood pressure Either sBP > 180 or dBP > 95 - Much too high

Table 1. DI@L-log decision support based on clinical practice guidelines

Feedback

- data is dynamically updated using JSP and relayed to the Hospital
- given in real-time to patient once all 3 values entered
- designed to be proactive, not to intimidate
- provides concise relevant information and a 'Call to Action' to empower patients ,

System: "The system will now update and process your new data...
 Your **weight** is falling and your **blood sugar** is well controlled. However, the **blood pressure** reading is slightly higher than the last time. If you can include some exercise, for example, 20 minutes of walking each day, this will help to lower your blood pressure. Also remember to reduce both salt and sugar intake at meal times. Well done, and keep up the good work!
 Thank you for calling the Dialogue Interactive Service.
 Please call again next Monday.... Goodbye."

Patient: Goodbye.

Human Factors and Considerations

Diverse user populations – patients and physicians

Cognitive demands and restrictions (motor, perceptory skills). Each user has individual needs – personalise the interaction

Patients will include the elderly, disabled and infirm

A clear mental model is necessary to familiarise patients with the Voice Logbook
No visual cues or icons- therefore consistency in prompts, and appropriate event handlers

User expectations from science fiction/attitudes and preconceptions.

Speech is transient, linear listening slow, communication is incremental; language ambiguity (eg accents)

Ethical/security considerations
(DTMF Keypad) Pin and passwords. VoiceXML incorporates SSL
Voxpilot facilitates ANI tracking to validate callers
Voice enrolment also considered.

Initial Results

- Most calls last 2-3 minutes in duration
- The average user takes nine turns to complete tasks-initially moderate level of recognition failures with digit input
- Callers prefer female voice over the male voice
- A personalised system (i.e. that greets the user by name) rather than formal system was preferred
- Every caller has been confident in speaking to the system, (however female subjects possibly more shy) and will revert to DTMF keypad where input hasn't been recognised via speech
- Peers have found the DI@L-log easy to use, and patients like the idea of a system that is not a real consultant monitoring them.

The Graphical User Interface

- Iteratively designed with health team
- ‘Target’ markers illustrate where reading ranges should be
- Documents temporal data parameters –trends
- Complements decision support/evidence based practice
- Additional Alerts functionality for abnormal trends/



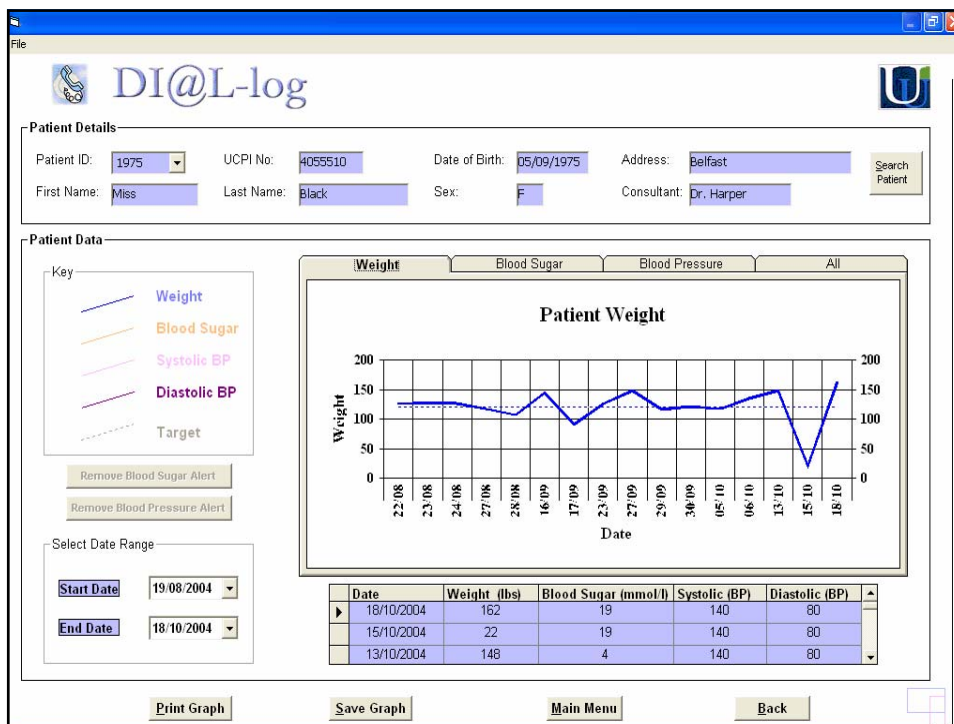

Alerts

- There are 2 alert categories – medium and high.
- Promote sense of shared responsibility
- Alert facility promotes earlier intervention and prevention of complications
 - For example: Blood sugar
 - If reading falls into category 4 for any two of three consecutive calls to the system, generate alert to caller –
“Your blood sugar is still too high. Your diabetes team has been informed and will contact you shortly”.
 - Presence of alert recorded in ‘Patient’ table in database.

patient : Table											
	patientid	ucpinum	firstname	lastname	dob	sex	phonenumber	address	consultant	pressurealert	sugaralert
+	1000	1001010	Patient	One	5/11/1951	M	02690 658745	Hollywood	Dr. Harper	Medium	
+	1001	1001110	Patient	Ten	7/05/1963	M	02991 486269	Canowdore	Dr. Harper	High	
+	1111	5041210	Connor	McMeel	1/01/1981	M	02690 566236	Belfast	Dr. Harding		High

Record: 14 | 2 | of 16

www.ulster.ac.uk

Evaluation and future work

- System performance and usability evaluation using qualitative and quantitative metrics.
- Does the system impinge on health professionals workflow practices?
- Improved patient quality of life & incentive?
- Show potential evidence for reduce costs of healthcare delivery?

Conclusions

- DI@L-log aims to improve the quality of diabetes care and establish appropriate techniques to accommodate individual patient preferences via an innovative speech communication platform that extends to a vast user audience.
- The autonomous nature of the system aims to replace the passive paper logbook and give patients empowerment and more responsibility in actively caring for their condition.
- Using telephony and spoken dialogue technology has many potential benefits over the static paper logbook or the GUI.
- It is argued that the provision of home monitored 'snapshots' via spoken dialogue telemedicine technologies is timely and complementary to the evolving patient-centric models of healthcare delivery i.e. keeping patients at home.

Acknowledgements



And special thanks to

- John Kennedy - Microsoft Corporation, USA
- Tim Bennett- DIAMOND EPR, UK
- George Fox - Voxpilot
- Conor McMeel