

Probability

The mathematical theory of *probability* is a way of formally representing and reasoning about uncertain events. In 1654, mathematicians [Blaise Pascal](#) and [Pierre de Fermat](#) corresponded about the odds for gambling outcomes and thus became co-founders of the theory of probability. In 1774, [Pierre-Simon Laplace](#) defined the probability of an event as the ratio of the number of favorable outcomes to the total number of possible outcomes. This definition only applies if all outcomes are equally likely, e.g. heads and tails are equally likely outcomes when we toss a fair coin but not equally likely when we toss a biased coin. In this document, we will follow Laplace and only events where all outcomes are equally likely. This is a pretty common occurrence and when it happens, the task of computing probabilities reduces to a task of counting. You will learn about more general probability when you take MTH U481 Probability and Statistics or ECN U350 Statistics.

1 Definitions and Basic Properties

An *experiment* or *random experiment* yields one of a possible set of outcomes. The *sample space* is the set of all possible outcomes. We will assume that all outcomes are equally likely. An *event* is a subset of the sample space, i.e. a set of outcomes.

The *probability* of an event E that is a subset of a finite sample space S is $p(E) = \frac{|E|}{|S|}$.

Let E , E_1 , and E_2 be events in sample space S . Then

$$p(\bar{E}) = 1 - p(E)$$

$$p(E_1 \cup E_2) = p(E_1) + p(E_2) - p(E_1 \cap E_2)$$

Examples

Dice - After all, it started with gambling.

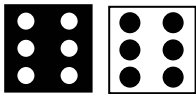

Experiment: Roll a pair of fair dice once.

- a) What is the size of the sample space?
There are 6 possibilities for the black die and 6 for the white one. By the product rule, there are a total of $6 \cdot 6 = 36$ possible tosses..

What is the probability of each of these events?

- b) The total is 6.
There are exactly 5 ways that the two dice that result in a sum of 6.

Black	1	2	3	4	5
White	5	4	3	2	1

So the probability of the sum being 6 is $5/36$.

- c) The total is 9.
There are exactly 4 ways that the two dice that result in a sum of 9.

Black	3	4	5	6
White	6	5	4	3

So the probability of the sum being 9 is $4/36 = 1/9$.

- d) The total is greater than 8.
There are exactly 4 ways that the two dice that result in a sum of 9,

Black	3	4	5	6
White	6	5	4	3

exactly 3 ways that the two dice that result in a sum of 10,

Black	4	5	6
White	6	5	4

exactly 2 ways that the two dice that result in a sum of 11,

Black	5	6
White	6	5

and one way that the two dice that result in a sum of 12.

Black	6
White	6

So the probability of a sum greater than 8 is $(4 + 3 + 2 + 1)/36 = 10/36 = 5/18$.

- e) The sum is seven or eleven.
There are exactly 2 ways that the two dice that result in a sum of 11

Black	5	6
White	6	5

and 6 ways that the sum can be 7.

Black	1	2	3	4	5	6
White	6	5	4	3	2	1

So the probability a 7 or 11 is $(2 + 6)/36 = 8/36 = 2/9$.

- r) Both dice have the same number.
There are 6 ways that the numbers can be the same.

Black	1	2	3	4	5	6
White	1	2	3	4	5	6

So the probability that the numbers are the same is $6/36 = 1/6$.

- g) The numbers are 4 and 3.
There are exactly 2 ways this can happen so the probability is $2/36 = 1/18$.

Black	3	4
White	4	3

- h) Snake-eyes
There is only one way this can happen so the probability is $1/36$.

Black	1
White	1

Cards - Still gambling

Experiment: Draw a single card from a normal 52 card deck.

- a) What is the size of the sample space?
Each card is a possible event. The size of the sample space is 52.

What is the probability of each of these events?

- b) The card is a face card.
There are 12 face cards (4 jacks, 4 queens, 4 kings) so the probability of a face card is $12/52 = 3/13$.
- c) The card is black.
Half the cards are black so the probability of drawing a black card is $1/2$.
- d) The card is a heart.
There are 13 hearts so the probability is $13/52 = 1/4$.
- e) The card is a queen.
There are 4 queens so the probability is $4/52 = 1/13$.
- f) The card is a number (2 through 10).
There are $4 \cdot 9 = 36$ number cards so the probability is $36/52 = 9/13$.
- g) The card is a joker.
The probability is 0. There are no jokers in a standard deck of 52 cards.
- h) The card is the Ace of Spades.
There is one Ace of Spades so the probability is $1/52$.

Urns

An urn contains 15 red balls and 10 blue balls.

A single ball is drawn.

- a) What is the size of the sample space?
There are 25 balls so the size of the sample space is 25. You might want to think of the red balls as numbered from 1 to 15 and the black ones as numbered from 1 to 10.

What is the probability of each of these events?

- b) The ball drawn is red.
There are 15 red balls so the probability is $15/25 = 3/5$.
- c) The ball drawn is blue.
There are 10 blue balls so the probability is $10/25 = 2/5$. Notice that $3/5 + 2/5 = 1$; drawing a red ball and drawing a blue ball are complementary events.

Three balls are drawn at once.

- a) What is the size of the sample space?
There are $C(25, 3) = \frac{25 \cdot 24 \cdot 23}{3 \cdot 2 \cdot 1} = 2300$.

What is the probability of each of these events?

- b) What is the probability that all three balls are red?
There are $C(15, 3) = \frac{15 \cdot 14 \cdot 13}{3 \cdot 2 \cdot 1} = 455$ ways of choosing 3 red balls so the probability is $455/2300 = 91/460$.
- c) What is the probability that two balls are red and one is blue?

There are $C(15,2) = \frac{15 \cdot 14}{2 \cdot 1} = 105$ ways of choosing 2 red balls and 10 ways of choosing 1 blue ball so there are $105 \cdot 10 = 1050$ ways of choosing 2 red balls and one blue one. The probability is $1050/2300 = 21/46$.

Three balls are drawn sequentially and each is returned to the urn before the next ball is drawn.

a) What is the size of the sample space?

There are 25 choices for each of the balls so there are $25^3 = 15625$ possible sequences of three balls (with replacement).

What is the probability of each of these events?

b) What is the probability that all three balls are red?

There are $15^3 = 3375$ sequences of three red balls (with replacement) so the probability is $\frac{15^3}{25^3} = \frac{3^3}{5^3} = \frac{27}{125}$.

c) What is the probability that two balls are red and one is blue?

There are 3 positions for the blue ball.

There are 10 balls that can go in this position.

There are $15^2 = 225$ sequences of two red balls for the remaining places.

In all, there are $3 \cdot 10 \cdot 15^2 = 6750$ outcomes with two red balls and one blue ball. The

probability of this event is $\frac{3 \cdot 10 \cdot 15^2}{25^3} = \frac{3 \cdot 2 \cdot 9}{5^3} = \frac{36}{125}$.

Bytes

Experiment: Toss a fair coin 8 times, 1 for heads, 0 for tails to generate a byte.

a) What is the size of the sample space?

There are $2^8 = 256$ bytes.

What is the probability of each of these events?

b) The byte has exactly four 1s.

Each byte with exactly four 1s corresponds to a subset of the 8 positions in the byte.

There are $C(8,4) = \frac{8 \cdot 7 \cdot 6 \cdot 5}{4 \cdot 3 \cdot 2 \cdot 1} = 70$ such subsets. Therefore, the probability of generating a byte with exactly four 1s is $70/256 = 35/128$.

c) The byte starts and ends with a 1.

The first and last positions in the byte are fixed but the other six places can be anything.

The number of such bytes is $2^6 = 64$ and the probability is $\frac{2^6}{2^8} = \frac{1}{4}$.

d) The byte starts and ends with the same bit.

There are twice as many bytes in the event than in part c. The probability is $1/2$.

e) The byte contains the substring 11111

Those with exactly 6 1s: 11111100, 01111110, 00111111

Those with exactly 7 1s: 11111110, 11111101, 01111111, 10111111

and one with 8 1s: 11111111.

$8/256 = 1/64$.

- f) The byte does not contain 2 consecutive 1s.
Think of making up the string from the 2-bit blocks, 00, 10, 01 with the constraint that 01 can only be followed by 00 or 01.

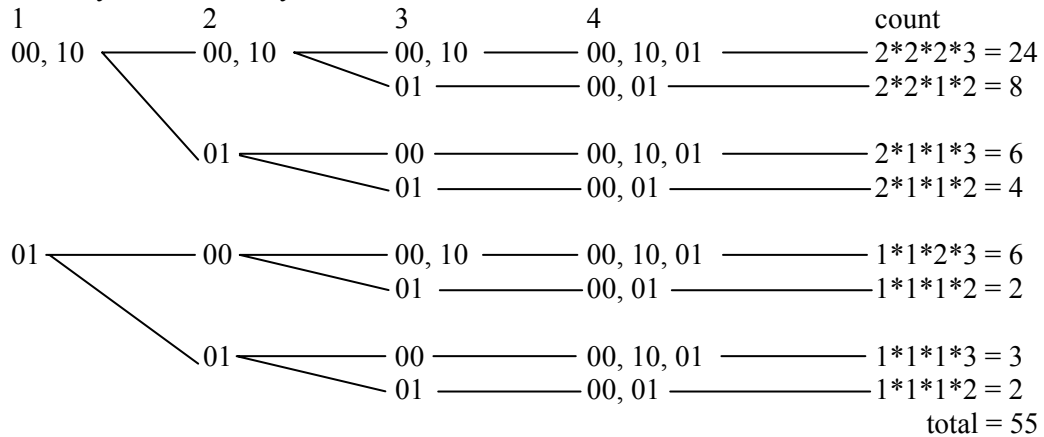

probability = $55/256$

Lottery

Ten balls numbered 1 to 10 are in a bag.

- a) What is the probability of drawing the ball numbered **8** on a single draw?
 $1/10$. There are 10 possible outcomes and only 1 successful outcome.
- b) What is the probability of drawing the ball numbered **8** in three draws if:
- i) The ball drawn is returned to the bag before the next selection?
There are $10^3 = 1000$ possible outcomes. There are $9^3 = 729$ outcomes that do not have an 8 in any draw. That leaves 271 outcomes that do contain an 8 so the probability is $271/1000$.
- ii) The balls are not returned to the bag before the next selection?
There are $10*9*8 = 720$ possible outcomes. There are $9*8*7 = 504$ possible outcomes that do not include an 8 in any of the three draws. That leaves $720 - 504 = 216$ outcomes that do include an 8 so the probability is $216/720 = 3/10$.
- c) What is the probability of drawing the sequence **9, 5, 2** in three draws if
- i) The ball drawn is returned to the bag before the next selection?
There is one successful outcome out of 1000 possible outcomes, $1/1000$.
- ii) The balls are not returned to the bag before the next selection?
There is one successful outcome out of $10*9*8 = 720$ possible outcomes, $1/720$.
- d) What is the probability of drawing the numbers **9, 5, 2** in any order in three draws if
- i) The ball drawn is returned to the bag before the next selection?
There are six successful outcomes out of 1000 possible outcomes, $6/1000 = 3/500$.
- ii) The balls are not returned to the bag before the next selection?
There are six successful outcomes out of 720 possible outcomes, $6/720 = 1/120$.